

EC-max 40 $\varnothing 40$ mm, brushless, 70 Watt

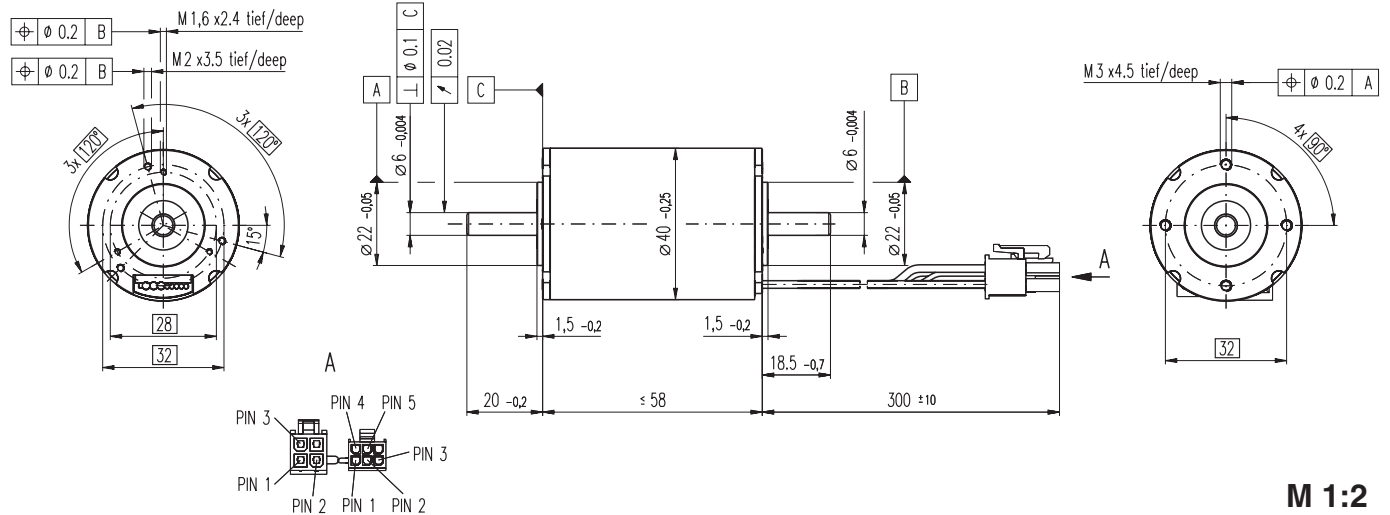

M 1:2

- Stock program
- Standard program
- Special program (on request)

Order Number

283866	283867	283868	283869
--------	--------	--------	--------

Motor Data

Values at nominal voltage		283866	283867	283868	283869	
1	Nominal voltage	V	12.0	24.0	36.0	48.0
2	No load speed	rpm	8020	8030	8450	9020
3	No load current	mA	631	316	228	190
4	Nominal speed	rpm	6490	6540	7050	7620
5	Nominal torque (max. continuous torque)	mNm	85.1	88.0	93.7	92.9
6	Nominal current (max. continuous current)	A	6.58	3.39	2.52	2.01
7	Stall torque	mNm	466	497	595	636
8	Starting current	A	33.3	17.8	14.9	12.7
9	Max. efficiency	%	75	76	77	78
Characteristics						
10	Terminal resistance phase to phase	Ω	0.360	1.35	2.42	3.78
11	Terminal inductance phase to phase	mH	0.0464	0.186	0.379	0.592
12	Torque constant	mNm / A	14.0	28.0	40.0	50.0
13	Speed constant	rpm / V	682	341	239	191
14	Speed / torque gradient	rpm / mNm	17.6	16.5	14.4	14.4
15	Mechanical time constant	ms	9.41	8.82	7.74	7.73
16	Rotor inertia	gcm ²	51.2	51.2	51.2	51.2

Specifications

Thermal data		
17	Thermal resistance housing-ambient	4.63 K / W
18	Thermal resistance winding-housing	0.542 K / W
19	Thermal time constant winding	3.76 s
20	Thermal time constant motor	926 s
21	Ambient temperature	-40 ... +100°C
22	Max. permissible winding temperature	+155°C
Mechanical data (preloaded ball bearings)		
23	Max permissible speed	12000 rpm
24	Axial play at axial load < 10 N	0 mm
	> 10 N	0.14 mm
25	Radial play	preloaded
26	Max. axial load (dynamic)	9 N
27	Max. force for press fits (static) (static, shaft supported)	170 N / 5000 N
28	Max. radial loading, 5 mm from flange	80 N

Operating Range

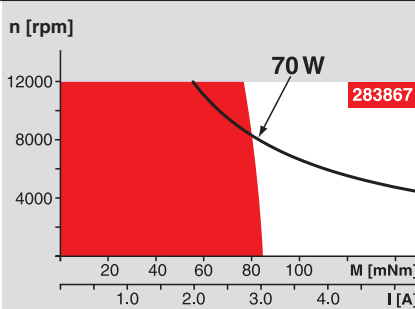

Comments

Continuous operation
In observation of above listed thermal resistance (lines 17 and 18) the maximum permissible winding temperature will be reached during continuous operation at 25°C ambient.
= Thermal limit.

Short term operation
The motor may be briefly overloaded (recurring).

— **Assigned power rating**

Other specifications

29	Number of pole pairs	1
30	Number of phases	3
31	Weight of motor	400 g

Values listed in the table are nominal.

Connection (Cable AWG 20)

red	Motor winding 1	Pin 1
black	Motor winding 2	Pin 2
white	Motor winding 3	Pin 3
	N.C.	Pin 4

Connector Article number

Molex	39-01-2040
-------	------------

Connection (Cable AWG 26)

yellow	Hall sensor 1	Pin 1
brown	Hall sensor 2	Pin 2
grey	Hall sensor 3	Pin 3
blue	GND	Pin 4
green	V _{Hall} 4.5 ... 24 VDC	Pin 5
	N.C.	Pin 6

Connector Article number

Molex	430-25-0600
-------	-------------

Wiring diagram for Hall sensors see page 26

maxon Modular System

1 **Planetary Gearhead**
 $\varnothing 42$ mm
3 - 15 Nm
Page 236

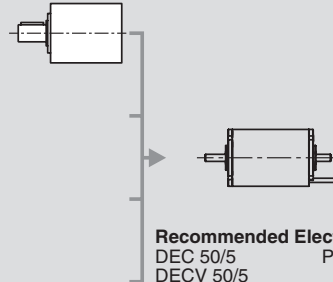

Recommended Electronics:

DEC 50/5	Page 277
DECV 50/5	278
DES 50/5	279
EPOS 24/5	286
EPOS P 24/5	287
MIP 50, 100	289
Notes	20

Overview on page 16 - 21

Encoder MR
500 / 1000 CPT,
3 channels
Page 251

Encoder HEDL 5540
500 CPT,
3 channels
Page 258

Brake AB 28
 $\varnothing 28$ mm
24 VDC, 0.4 Nm
Page 299